

SCHOTTKY BARRIER RECTIFIER

VOLTAGE RANGE: 20 --- 200 V
CURRENT: 8.0A

FEATURES

- ◇ Metal-semiconductor junction with guard ring
- ◇ Epitaxial construction
- ◇ Low forward voltage drop, low switching losses
- ◇ High surge capability
- ◇ For use in low voltage, high frequency inverters free wheeling, and polarity protection applications
- ◇ The plastic material carries U/L recognition 94V-0

MECHANICAL DATA

- ◇ Case: JEDEC TO-263, molded plastic
- ◇ Terminals: Axial lead, solderable per MIL-STD-750, Method 2026
- ◇ Polarity: As marked
- ◇ Weight: 0.08 ounces, 2.24 grams
- ◇ Mounting position: Any

TO - 263

D2PAK

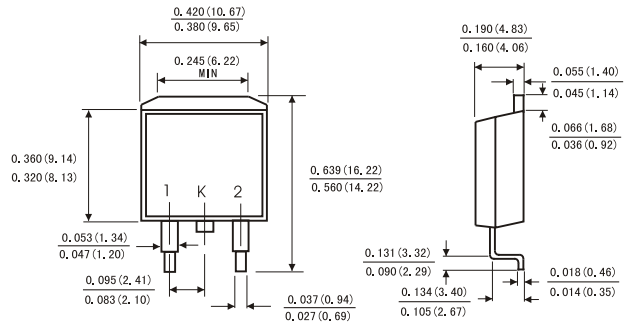

MAXIMUM RATINGS AND ELECTRICAL CHARACTERISTICS

Ratings at 25°C ambient temperature unless otherwise specified.

Single phase, half wave, 60 Hz, resistive or inductive load. For capacitive load, derate by 20%.

	Symbols	MBR 820CT	MBR 830CT	MBR 840CT	MBR 850CT	MBR 860CT	MBR 880CT	MBR 8100CT	MBR 8150CT	MBR 8200CT	Units
Maximum repetitive peak reverse voltage	V _{RRM}	20	30	40	50	60	80	100	150	200	Volts
Maximum RMS voltage	V _{RMS}	14	21	28	35	42	56	70	105	140	Volts
Maximum DC blocking voltage	V _{DC}	20	30	40	50	60	80	100	150	200	Volts
Maximum average forward rectified current (see Fig. 1)	Per leg	4.0									Amps
	Total device	8.0									
Peak forward surge current 8.3ms single half sine-wave superimposed on rated load (JEDEC method)	I _{FSM}	150.0									Amps
Maximum instantaneous forward voltage at 8.0 A (Notes 1)	V _F	0.60		0.75		0.85		0.90		0.95	Volts
Maximum instantaneous reverse current at rated DC blocking voltage (Notes 1)	I _R	0.2									mA
		15			50						
Typical thermal resistance (Notes 2)	R _{θJC}	2.5									°C/W
Operating junction temperature range	T _J	-65 to +150									°C
Storage temperature range	T _{STG}	-65 to +150									°C

- NOTE: 1. Pulse test: 300us pulse width, 1% duty cycle.
2. Measured at 1.0MHz and applied reverse voltage of 4.0V DC.
3. Thermal resistance junction to ambient

FIG.1-FORWARD CURRENT DERATING CURVE

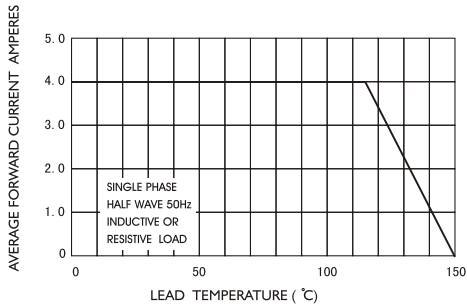

FIG.2-TYPICAL INSTANTANEOUS FORWARD CHARACTERISTICS

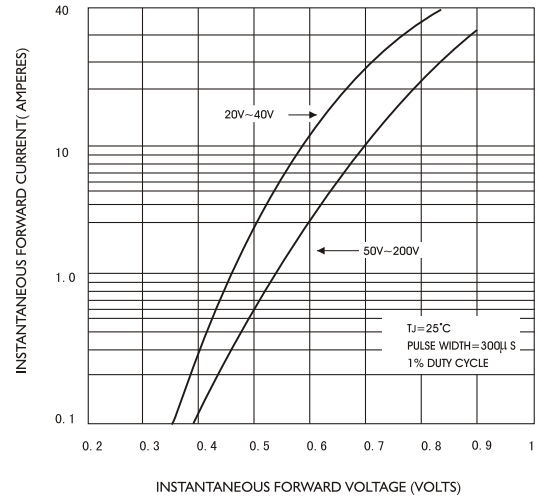

FIG.4-TYPICAL JUNCTION CAPACITANCE

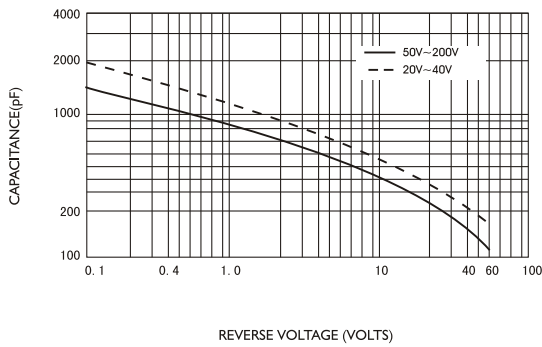

FIG.3-TYPICAL REVERSE CHARACTERISTICS

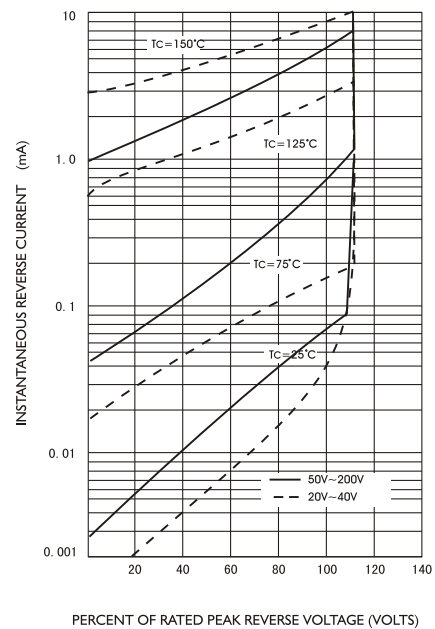

FIG.5-MAXIMUM NON-REPETITIVE PEAK FORWARD SURGE CURRENT

